

# COMMERCIAL DATA SHEET

## Quadra 440 XL

# Billi™

### Billi Quadra 440 with XL Levered Dispenser

The Quadra 440 Boiling and Chilled drinking water system is a water cooled, medium capacity, commercial drinking water solution.

Our Quadra boiling and chilled range incorporates Billi's core design principles - standing out for its use of innovative energy reclaim technology. Not only does the system save space and energy, but it also eliminates the need for joinery ventilation to transfer waste heat. This technology is backed by the Global Green Tag accreditation.

Streamlined and elegant, the XL levered dispenser offers boiling and chilled output delivered safely by operating the position-sensitive levers.



**BOILING**



**CHILLED**



XL Levered Dispenser

Quadra Under-Bench Unit



### Features



SPACE SAVING DESIGN



SAFE TO OPERATE



ENERGY EFFICIENT



HEAT EXCHANGE TECHNOLOGY



NO CUPBOARD VENTILATION REQUIRED



GREENTAG CERTIFIED





EASY INSTALLATION



WATER COOLED TECHNOLOGY

## PRODUCT SPECIFICATIONS

Water type	Product code	Model name	Dispenser	Suggested no. of people	Boiling water delivery (cups per hour)*	Chilled water delivery (cups per hour)	Power supply (amps)
  <b>BOILING CHILLED</b>	904040LUK	Quadra 440	XL Levered	Up to 40	150	175	13

\* Based on a set volume of water being drawn every 30 seconds at an inlet temperature of average temperature 21°C. Each cup is equivalent to 170ml. Usage patterns and draw-off methods can impact recovery.

### Accessories

**992803** - 120mm Riser & Font

**990720** - Tubing Extension Kit for X series dual temp dispensers 2mtrs



### Finishes

Standard Finishes

CH - Chrome

BR - Brushed

MB - Matte Black

Special Order Finishes

MW - Matte White

RG - Rose Gold

BRG - Brushed Rose Gold

GM - Gun Metal Grey

UB - Urban Brass

Add the relevant Finish Code and the Country Identifier (UK) to the Product code to complete your specification eg 904040LMBUK

# TECHNICAL DRAWING & INSTALLATION REQUIREMENTS

## PRODUCT DIMENSIONS

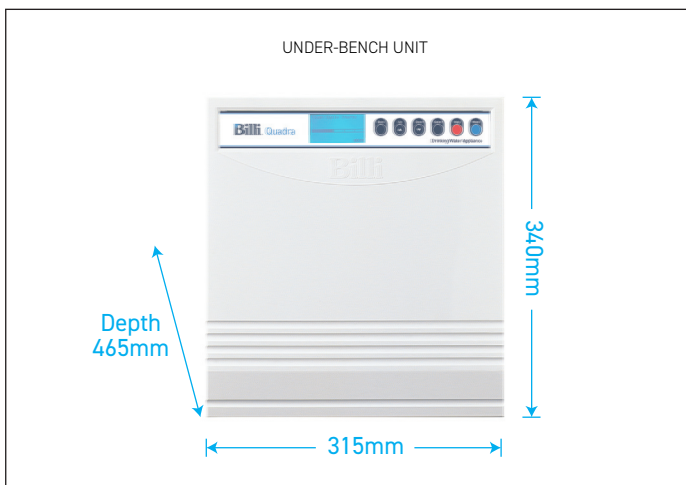
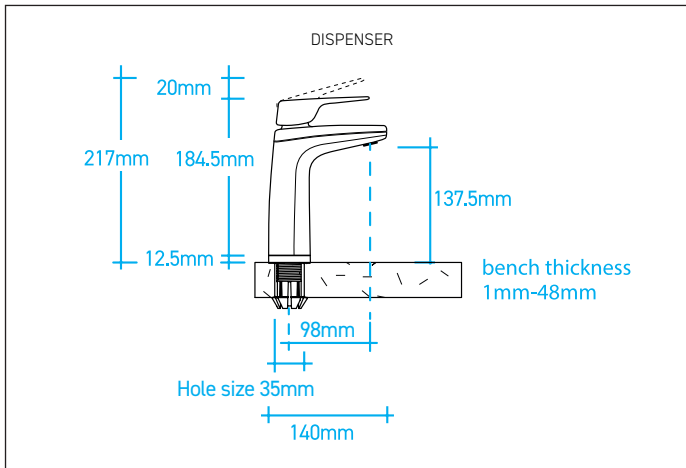

## PREFERRED INSTALLATION LAYOUT

Refer to installation requirements, these drawings are for guidance only.

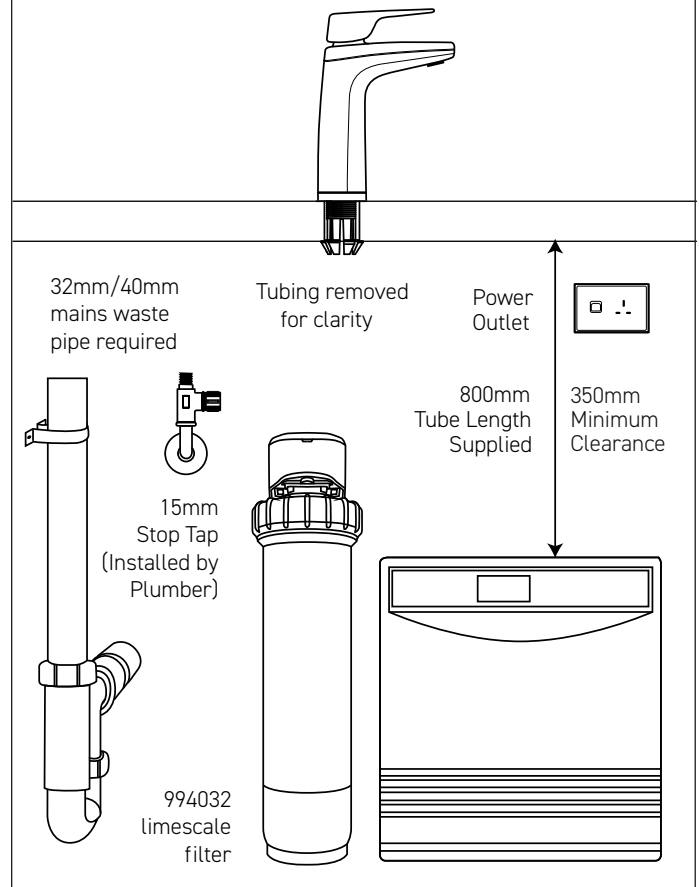

### WATER SUPPLY

An accessible drinking water supply from a 15mm pipe with a minimum pressure of 2.5bar static and 6 litres a minute flow should be located in the base unit of the installation location.

### POWER SUPPLY

A 13amp single switched socket must be positioned at a high level and accessible within the cupboard. The unit comes with a 1 meter flex cord and plug.

### WASTE REQUIREMENTS

A 32mm/40mm mains waste pipe is required within the base unit. This pipe should include a trap or u-bend to prevent any unpleasant odours. If there is a spigot waste connection, two spigots are required to connect to the waste and condenser line.

### WARRANTY

The Billi Quadra Range is covered by a comprehensive 2 year warranty on all parts and labour.

### FILTRATION

Billi's range of premium filters utilise BWT's unique Fibron X technology, which provide superior taste, water quality, consistent filter life and peace of mind on the topic of hygiene.

Supplied: 994051 (5 micron)

On request: 994032 (recommended iX02 limescale filter)

### CERTIFICATIONS & COMPLIANCE\*

Every Billi drinking water appliance is manufactured under a certified quality control system. All Billi commercial range models have been tested and comply with all required standards including: ISO 9001:2015, QEC 11627; WRAS certified; WELL Cornerstone Member; BREAMM compliant; LEED compliant; Global Greentag Certified.

\* Drawings are for guidance during specification, refer to Installation requirements for final install. All efforts are made to ensure Certifications & Compliance claims are current, however this is subject to change without notice.

# Billi™

### Billi UK Limited

University Of Wolverhampton Science Park,  
Technology Centre, Glaisher Drive,  
Wolverhampton, WV10 9RU

**P** 020 7456 6789  
**E** marketing@billi-uk.com  
**W** www.billi-uk.com

visit us at

