

# COMMERCIAL DATA SHEET

## Sahara 360 XT

# Billi™

### Billi Sahara 360 with XT Touch Dispenser

The Sahara 360 Boiling and Ambient drinking water system is a mid-range commercial capacity system, but still maintains Billi's core design principles of space saving while requiring no joinery ventilation.

Offering both boiling temperature water and a bottomless supply of filtered ambient temperature water, the Sahara range is convenient and functional.

The XT touch is an innovative dispenser, featuring a contemporary design incorporating a touch panel to offer a sophisticated and clean style.



BOILING

STILL



XT Touch Dispenser

Sahara Under-Bench Unit



### Features



SPACE SAVING DESIGN



SAFE TO OPERATE



SPLASHFREE DELIVERY



NO CUPBOARD VENTILATION REQUIRED





EASY INSTALLATION



ENERGY EFFICIENT

## PRODUCT SPECIFICATIONS

Water type	Product code	Model name	Dispenser	Suggested no. of people	Boiling water delivery (cups per hour)*	Still water delivery (cups per hour)	Power supply (amps)
  BOILING STILL	943060TUK	Sahara 360	XT Touch	Up to 60	Up to 165	unlimited	13

\* Based on a set volume of water being drawn every 30 seconds at an inlet temperature of average temperature 21°C. Each cup is equivalent to 170ml. Usage patterns and draw-off methods can impact recovery.

### Accessories

992803 - 120mm Riser & Font

990720 - Tubing Extension Kit for X series dual temp dispensers 2mtrs



### Finishes

Standard Finishes

CH - Chrome    BR - Brushed    MB - Matte Black

Special Order Finishes

MW - Matte White    RG - Rose Gold

Add the relevant Finish Code and the Country Identifier (UK) to the Product code to complete your specification eg 943060TMBUK

# TECHNICAL DRAWING & INSTALLATION REQUIREMENTS

## PRODUCT DIMENSIONS

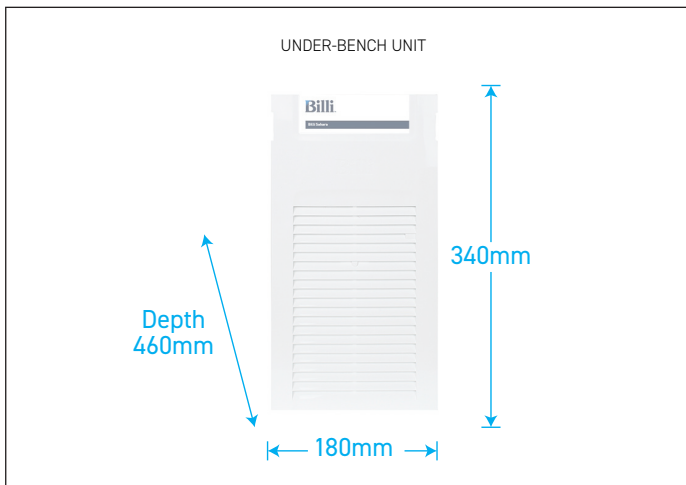
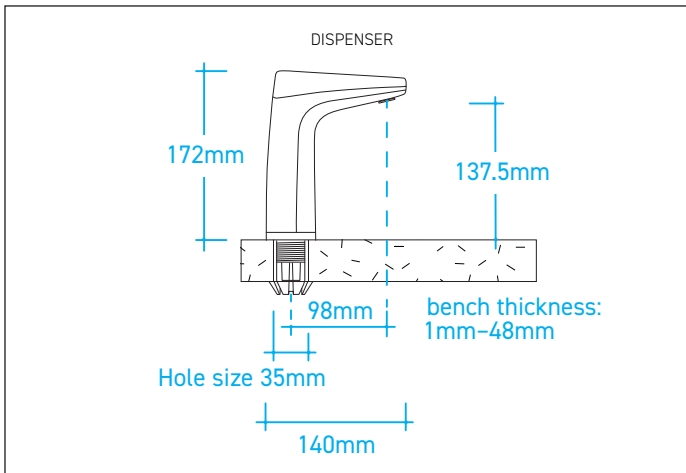

## PREFERRED INSTALLATION LAYOUT

Refer to installation requirements, these drawings are for guidance only.

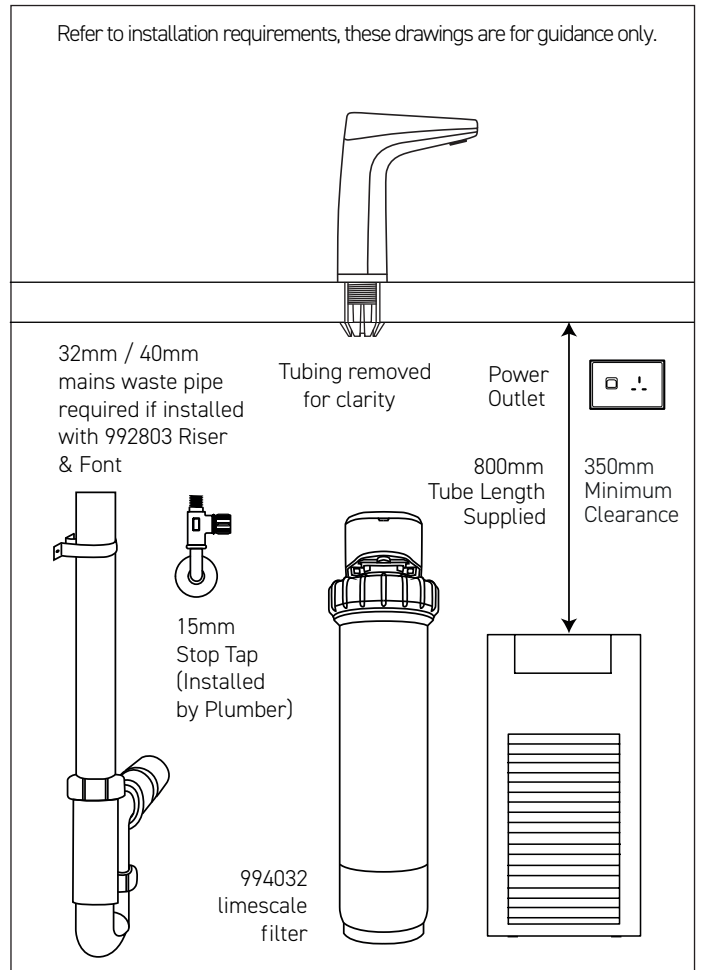

### WATER SUPPLY

An accessible drinking water supply from a 15mm pipe with a minimum pressure of 2.5bar static and 6 litres a minute flow should be located in the base unit of installation location.

### POWER SUPPLY

A 13amp single switched socket must be positioned at a high level and accessible within the cupboard. The unit comes with a 1 meter flex cord and plug.

### WASTE REQUIREMENTS

A 32mm/40mm mains waste pipe is required within the base unit. This pipe should include a trap or u-bend to prevent any unpleasant odours. A suitable spigot waste is also acceptable. Where the tap installed over a sink, waste is not required. When installed on a drainage font - then use the existing waste instructions already on the document

### WARRANTY

The Billi Sahara Range is covered by a comprehensive 2 year warranty on all parts and labour.

### FILTRATION

Billi's range of premium filters utilise BWT's unique Fibron X technology which provide superior taste, water quality, consistent filter life and peace of mind on the topic of hygiene.

Supplied: 994051 (5 micron)

On request: 994032 (recommended iX02 limescale filter)

### CERTIFICATIONS & COMPLIANCE\*

Every Billi drinking water appliance is manufactured under a certified quality control system. All Billi commercial range models have been tested and comply with all required standards including: ISO 9001:2015, QEC 11627; WRAS certified; WELL Cornerstone Member; BREAMM compliant; LEED compliant.

\* Drawings are for guidance during specification, refer to Installation requirements for final install. All efforts are made to ensure Certifications & Compliance claims are current, however this is subject to change without notice.

# Billi™

### Billi UK Limited

University Of Wolverhampton Science Park,  
Technology Centre, Glaisher Drive,  
Wolverhampton, WV10 9RU

**P** 020 7456 6789  
**E** marketing@billi-uk.com  
**W** www.billi-uk.com

visit us at

