

COMMERCIAL DATA SHEET

Alpine 125 XL



Billi Alpine 125 with XL Levered Dispenser

Enjoy refreshing chilled or a continuous supply of ambient temperature filtered water.

Billi's Alpine 125 offers a premium filtered drinking water experience to account for all preferences.

The XL levered dispenser is streamlined and elegant, offering chilled and ambient output delivered safely by operating the position-sensitive levers.



XL Levered Dispenser

Alpine Under-Bench Unit



Features



SPACE SAVING DESIGN



ENERGY EFFICIENT



NO CUPBOARD VENTILATION REQUIRED



UNLIMITED FILTERED WATER



WATER COOLED TECHNOLOGY





ADJUSTABLE CHILLED TEMPERATURE



CHOICE OF DISPENSER DESIGNS

PRODUCT SPECIFICATIONS

Water type	Product code	Model name	Dispenser	Suggested no. of people	Chilled water delivery (cups per hour)	Still water delivery (cups per hour)	Power supply (amps)
  STILL CHILLED	932125LUK	Alpine 125	XL Levered	Up to 40	120	unlimited	13

Accessories

992803 - 120mm Riser & Font

990720 - Tubing Extension Kit for X series dual temp dispensers 2mtrs



Finishes

Standard Finishes

CH - Chrome

BR - Brushed

MB - Matte Black

Special Order Finishes

MW - Matte White

RG - Rose Gold

BRG - Brushed Rose Gold

GM - Gun Metal Grey

UB - Urban Brass

Add the relevant Finish Code and the Country Identifier (UK) to the Product code to complete your specification eg 932125LMBUK

TECHNICAL DRAWING & INSTALLATION REQUIREMENTS

PRODUCT DIMENSIONS

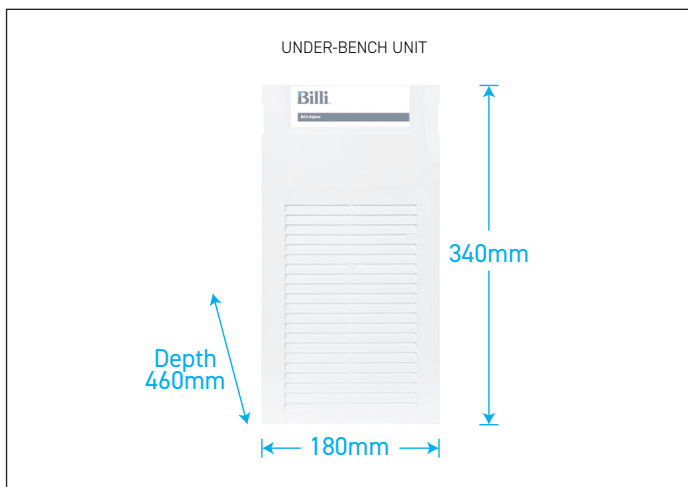
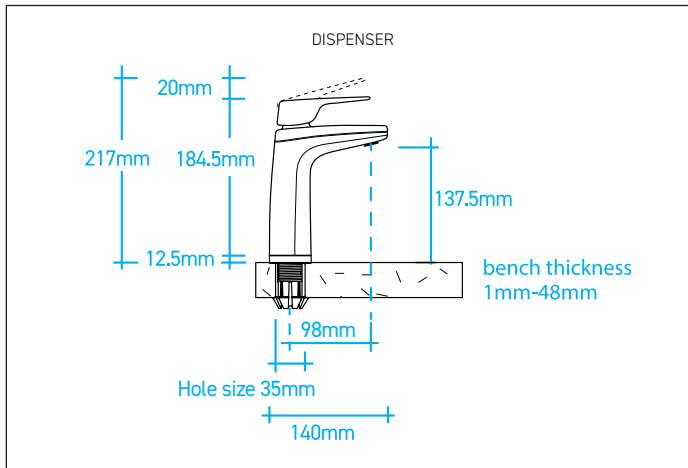

PREFERRED INSTALLATION LAYOUT

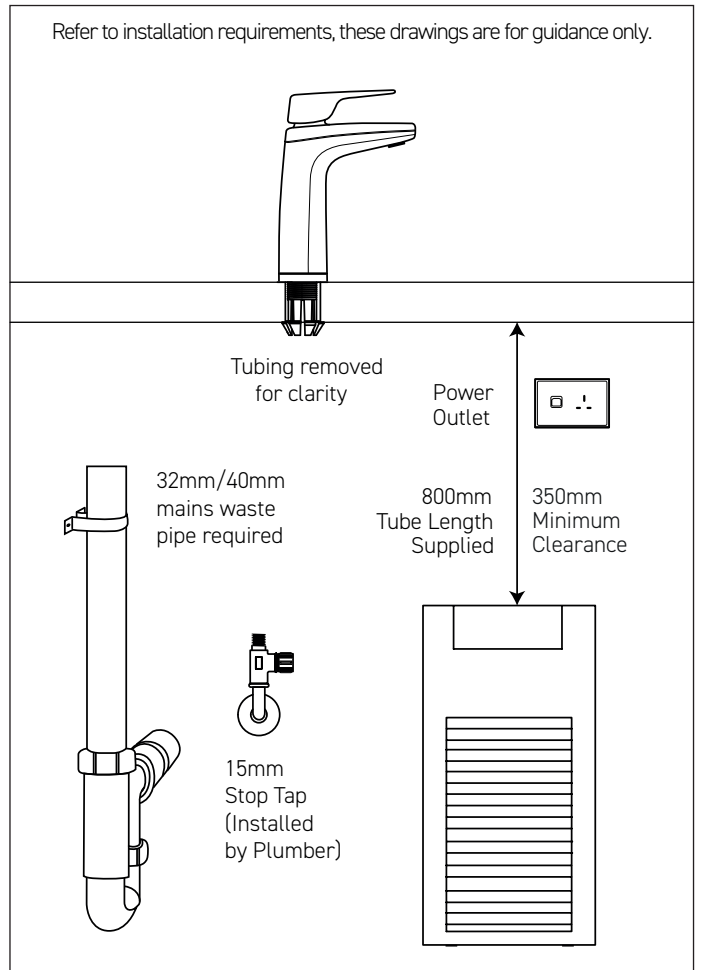

WATER SUPPLY

An accessible drinking water supply from a 15mm pipe with a minimum pressure of 2.5bar static and 6 litres a minute flow should be located in the base unit of the installation location.

POWER SUPPLY

A 13amp single switched socket must be positioned at a high level and accessible within the cupboard. The unit comes with a 1 meter flex cord and plug.

WASTE REQUIREMENTS

A 32mm/40mm mains waste pipe is required within the base unit. This pipe should include a trap or u-bend to prevent any unpleasant odours. If there is a spigot waste connection, two spigots are required to connect to the waste and condenser line.

WARRANTY

The Billi Alpine Range is covered by a comprehensive 2 year warranty on all parts and labour.

FILTRATION

Billi's range of premium filters utilise BWT's unique Fibron X technology which provide superior taste, water quality, consistent filter life and peace of mind on the topic of hygiene.

Supplied: 994051 (5 micron).

CERTIFICATIONS & COMPLIANCE*

Every Billi drinking water appliance is manufactured under a certified quality control system. All Billi commercial range models have been tested and comply with all required standards including: ISO 9001:2015, QEC 11627; WRAS certified; WELL Cornerstone Member; BREAMM compliant; LEED compliant.

* Drawings are for guidance during specification, refer to Installation requirements for final install. All efforts are made to ensure Certifications & Compliance claims are current, however this is subject to change without notice.

Billi™

Billi UK Limited

University Of Wolverhampton Science Park,
Technology Centre, Glaisher Drive,
Wolverhampton, WV10 9RU

P 020 7456 6789
E marketing@billi-uk.com
W www.billi-uk.com

visit us at

