

# COMMERCIAL DATA SHEET

## Alpine 125 XR Remote



### Billi Alpine 125 with XR Remote Dispenser

Enjoy refreshing chilled or a continuous supply of ambient temperature filtered water.

Billi's Alpine 125 offers a premium filtered drinking water experience to account for all preferences.

The XR remote dispenser is an innovative design around accessibility, which utilises a remote-control panel to provide inclusive access for ambulant or wheelchair users.



XR Remote Dispenser

Alpine Under-Bench Unit



### Features



## PRODUCT SPECIFICATIONS

Water type	Product code	Model name	Dispenser	Suggested no. of people	Chilled water delivery (cups per hour)	Still water delivery (cups per hour)	Power supply (amps)
 STILL CHILLED	932125RUK	Alpine 125	XR Remote	Up to 40	120	unlimited	13

### Accessories

**992803** - 120mm Riser & Font

**990720** - Tubing Extension Kit for X series dual temp dispensers 2mtrs



### Finishes

#### Standard Finishes

CH - Chrome

BR - Brushed

MB - Matte Black

#### Special Order Finishes

MW - Matte White

RG - Rose Gold

As a fit for purpose solution to comply with the Equality Act 2010, the specification code is 932125RCHUK

# TECHNICAL DRAWING & INSTALLATION REQUIREMENTS

## PRODUCT DIMENSIONS

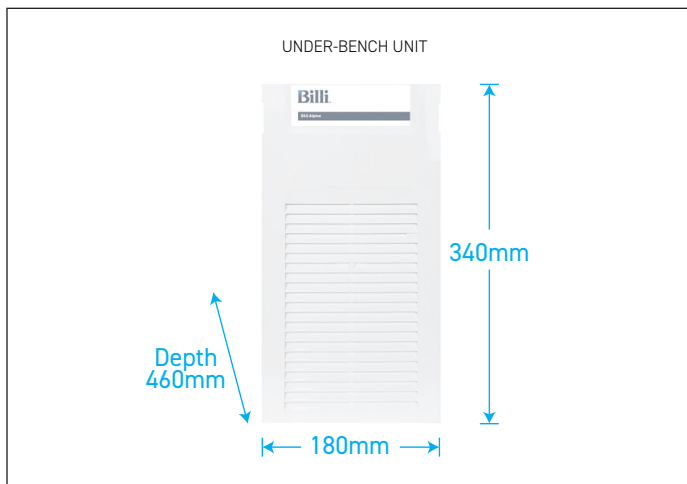
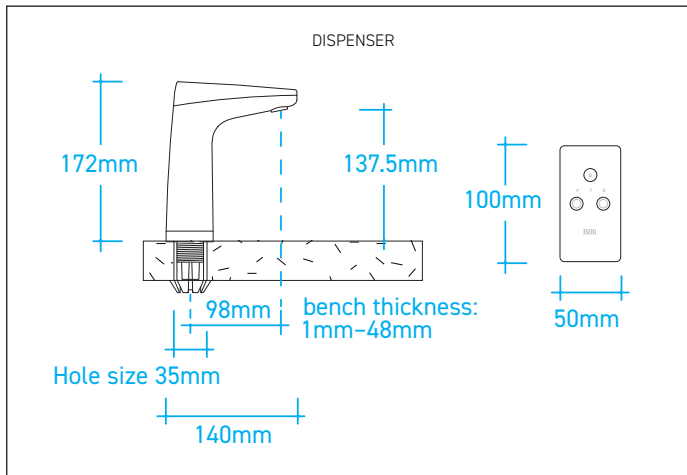

## PREFERRED INSTALLATION LAYOUT

Refer to installation requirements, these drawings are for guidance only.

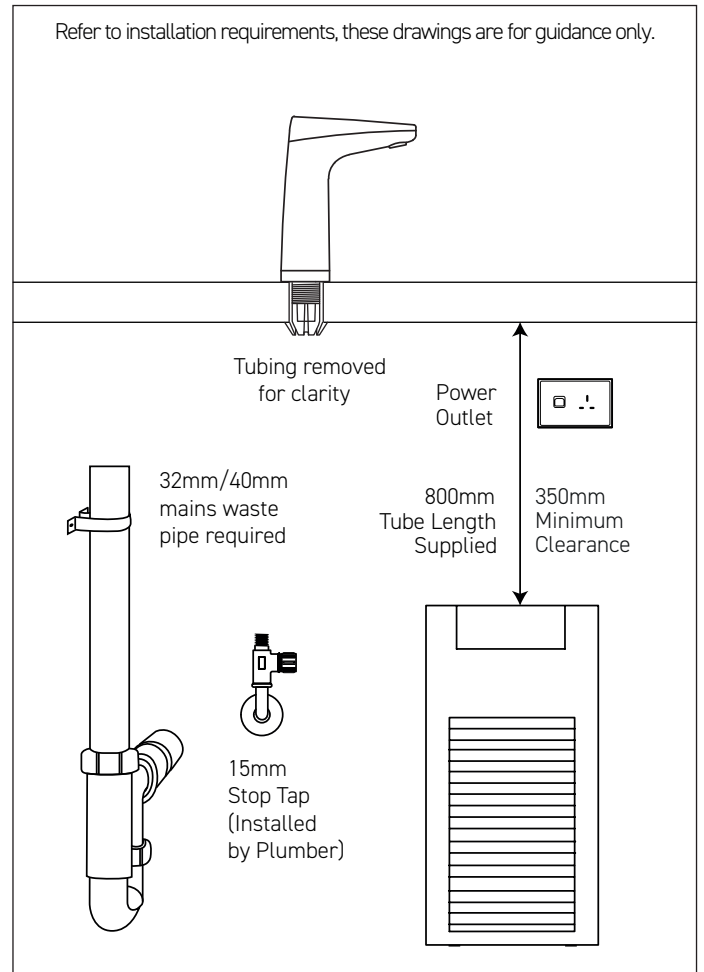

### WATER SUPPLY

An accessible drinking water supply from a 15mm pipe with a minimum pressure of 2.5bar static and 6 litres a minute flow should be located in the base unit of the installation location.

### POWER SUPPLY

A 13amp single switched socket must be positioned at a high level and accessible within the cupboard. The unit comes with a 1 meter flex cord and plug.

### WASTE REQUIREMENTS

A 32mm/40mm mains waste pipe is required within the base unit. This pipe should include a trap or u-bend to prevent any unpleasant odours. If there is a spigot waste connection, two spigots are required to connect to the waste and condenser line.

### WARRANTY

The Billi Alpine Range is covered by a comprehensive 2 year warranty on all parts and labour.

### FILTRATION

Billi's range of premium filters utilise BWT's unique Fibron X technology which provide superior taste, water quality, consistent filter life and peace of mind on the topic of hygiene.

Supplied: 994051 (5 micron).

### CERTIFICATIONS & COMPLIANCE\*

Every Billi drinking water appliance is manufactured under a certified quality control system. All Billi commercial range models have been tested and comply with all required standards including: ISO 9001:2015, QEC 11627; WRAS certified; WELL Cornerstone Member; BREAMM compliant; LEED compliant;

\* Drawings are for guidance during specification, refer to Installation requirements for final install. All efforts are made to ensure Certifications & Compliance claims are current, however this is subject to change without notice.

# Billi™

### Billi UK Limited

University Of Wolverhampton Science Park,  
Technology Centre, Glaisher Drive,  
Wolverhampton, WV10 9RU

**P** 020 7456 6789  
**E** marketing@billi-uk.com  
**W** www.billi-uk.com

visit us at

