

COMMERCIAL DATA SHEET

Quadra Sparkling 460 XL



Billi Quadra Sparkling 460 with XL Levered Dispenser

The Quadra Sparkling 460 is the ultimate choice in modern design and filtered drinking water appliances, delivering instant boiling and chilled filtered water, with the added luxury of sparkling water.



BOILING



CHILLED



SPARKLING



Up to 60

Utilising under counter Water Cooled Technology to enhance capacity and recovery, all three water output options are conveniently provided by operating the position-sensitive levers on our XL Levered dispenser.

XL Levered Dispenser

Quadra Sparkling Under-Bench Unit

Features



SPACE SAVING DESIGN



SAFE TO OPERATE



ENERGY EFFICIENT



HEAT EXCHANGE TECHNOLOGY



NO CUPBOARD VENTILATION REQUIRED



GREENTAG CERTIFIED



EASY INSTALLATION



WATER COOLED TECHNOLOGY

PRODUCT SPECIFICATIONS

Water type	Product code	Model name	Dispenser	Suggested no. of people	Boiling water delivery (cups per hour)*	Chilled & Sparkling water delivery (cups per hour)	Power supply (amps)
BOILING CHILLED SPARKLING	906060LUK	Quadra Sparkling 460	XL Levered	Up to 60	180	200	2 x13

* Based on a set volume of water being drawn every 30 seconds at an inlet temperature of average temperature 21°C. Each cup is equivalent to 170ml. Usage patterns and draw-off methods can impact recovery.

Accessories

992803 - 120mm Riser & Font

990720 - Tubing Extension Kit for X series dual temp dispensers 2mtrs



Finishes

Standard Finishes

CH - Chrome

BR - Brushed

MB - Matte Black

Special Order Finishes

MW - Matte White

RG - Rose Gold

BRG - Brushed Rose Gold

GM - Gun Metal Grey

UB - Urban Brass

Add the relevant Finish Code and the Country Identifier (UK) to the Product code to complete your specification eg 906060LMBUK

TECHNICAL DRAWING & INSTALLATION REQUIREMENTS

PRODUCT DIMENSIONS

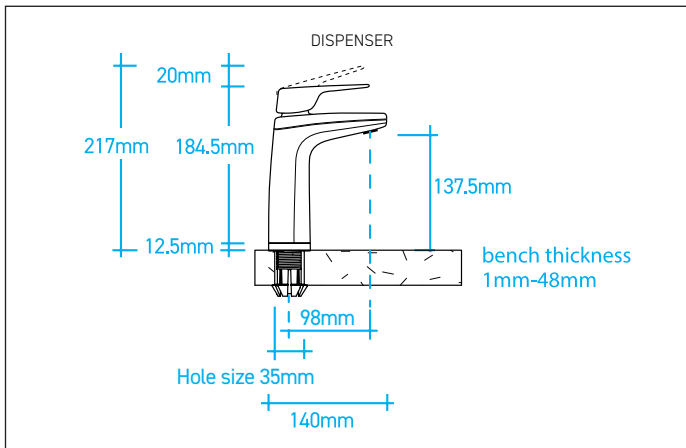

PREFERRED INSTALLATION LAYOUT

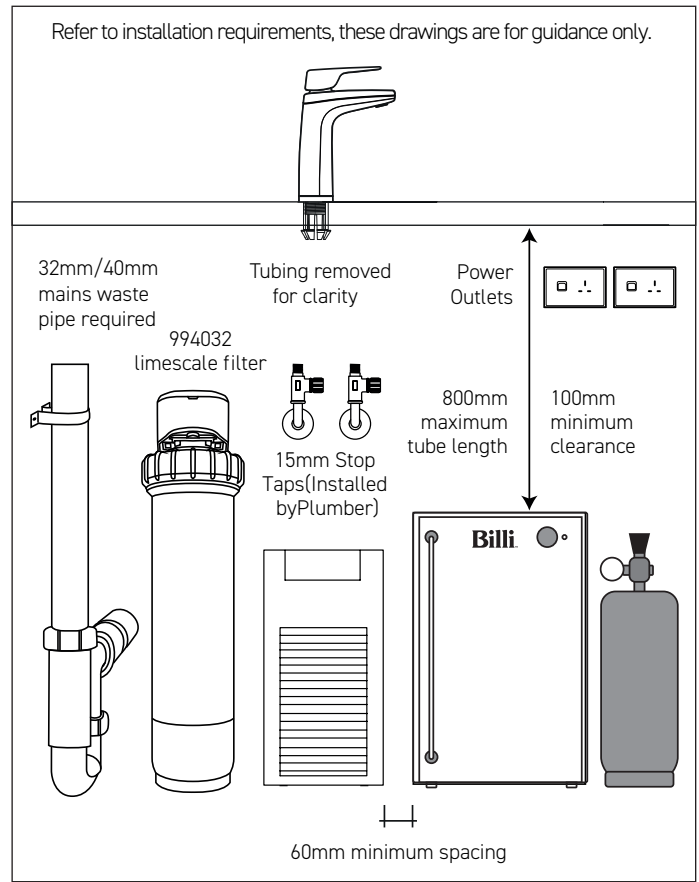

WATER SUPPLY

an accessible drinking water supply from a 15mm pipe with a minimum pressure of 2.5bar static and 6 litres a minute flow should be located in the base unit of the installation location.

POWER SUPPLY

A 13amp double switched socket must be positioned at a high level and accessible within the cupboard. The unit comes with a 1 meter flex cord and plug.

WASTE REQUIREMENTS

A 32mm/40mm mains waste pipe is required within the base unit. This pipe should include a trap or u-bend to prevent any unpleasant odours. If there is a spigot waste connection, two spigots are required to connect to the waste and condenser line.

FILTRATION

Billi's range of premium filters utilise BWT's unique Fibron X technology which superior taste, water quality, consistent filter life and peace of mind on the topic of hygiene.

Supplied: 994051 (5 micron)

On request: 994032 (recommended iX02 limescale filter)

CO₂ Cylinder

The CO₂ gas cylinder supplied must be secured in a suitable location. Each cylinder contains 1100g of CO₂ and should be installed in a well ventilated area. Each cylinder will provide 160 litres of sparkling water depending on the unit settings. The MSDS is available on www.billi-uk.com for a complete list of specifications and warnings. Replacement gas cylinders are available from Billi. CO₂ Cylinder - Order code 996911 and select chosen quantity (single, twin, 6-pack).

WARRANTY

The Billi Quadra Range is covered by a comprehensive 2 year warranty on all parts and labour.

CERTIFICATIONS & COMPLIANCE*

Every Billi drinking water appliance is manufactured under a certified quality control system. All Billi commercial range models have been tested and comply with all required standards including: WRAS certified; WELL Cornerstone Member; BREAMM compliant; LEED compliant; Equality Act Compliant.

* Drawings are for guidance during specification, refer to Installation requirements for final install. All efforts are made to ensure Certifications & Compliance claims are current, however this is subject to change without notice.

Billi™

Billi UK Limited

University Of Wolverhampton Science Park,
Technology Centre, Glaisher Drive,
Wolverhampton, WV10 9RU

P 020 7456 6789

E marketing@billi-uk.com

W www.billi-uk.com

visit us at

