

BilliTM



Install Guide

Alpine 120

Installation requirements.

—Components for Alpine 120

Before commencing installation, ensure you have identified the following.

1. Chilled Water Module
2. Installation Requirements
3. Installation Hardware and Dispenser
4. Warranty

—Water Supply

A single cold water supply is required.

Supply Pressure: 200 – 1000 Kpa

Supply Temperature: 5°C – 30°C

Do not install with water that is microbiologically unsafe or with water of unknown quality without adequate disinfection before or after the system. Systems certified for cyst reduction may be used on disinfected water that may contain filterable cysts.

—Power Requirements

A single 13 amp standard power outlet is required. Chiller module is supplied with 1 metre of flex cord and plug.

—Drainage

A drainage point, such as a dishwasher nipple or a tundish, is required. An air gap is provided within the tap assembly.

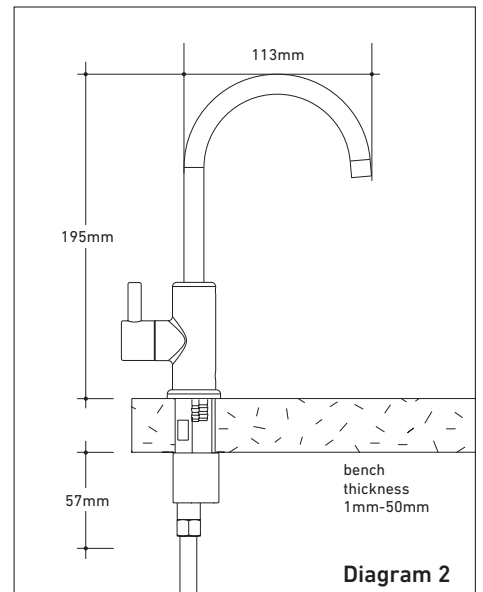
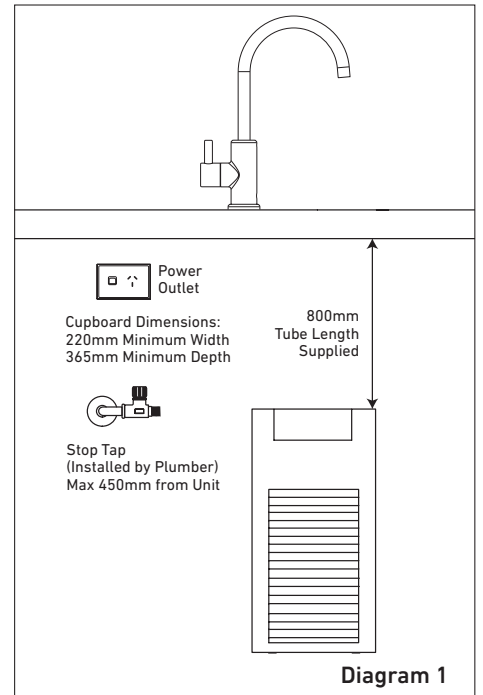

Installing the dispenser.

IMPORTANT: This Billi appliance is to be installed by a licensed tradesperson in accordance with AS/NZ 3500 and in compliance with applicable state regulatory requirements. For correct operation of this appliance, it is essential to observe the manufacturer's instructions.

1. Determine Component Location

A stop tap (not supplied) is to be installed in an easily accessible position for later service. Determine the location of each of the components, taking into account the tube lengths and space available. Refer to Diagrams 1 & 2.

2. Mount Backflow Prevention/ Pressure Regulator Valves

Fit combined backflow prevention/ pressure limiting valve (supplied) to stop tap in accordance with enclosed manufacturer's instructions.

3. Flush Lines

It is important to flush lines before fitting. Install outlet fitting to combined valve. Refer to Diagram 4.

4. Install Dispenser Tap Assembly

DISPENSER MUST NOT BE INSTALLED BELOW THE SPILL LEVEL OF THE RECEIVING FIXTURE.

A 22mm hole is required either in the benchtop or flat surface of sink adjacent to bowl of sink. Mount the dispenser tap. Refer to Diagram 3.

5. Install Chiller Module

Connect all plastic tubing as shown. Refer to Diagram 4. All connections are made using push-fit connectors. Trim tubes to correct lengths. Tubes should be cleanly cut square using a sharp knife or plastic tube cutter. Ensure that tube ends are round and not flattened or kinked, then push into connectors firmly until properly seated (to release, press the outer ring in while pulling gently on the tube).

6. Install Drain Connection

The Billi dispenser tap incorporates an air break above the spill level of the sink and therefore a tundish is not required. Connect a 3/8" drain tube to dishwasher nipple, or alternative drainage point, using fittings supplied.

ENSURE DRAIN TUBE HAS A CONTINUAL FALL.

7. Turn on Water Supply

Pull dispenser tap lever and then turn on water supply. After water flows from outlet, release lever and ensure that there are no leaks. Pull lever again and run for at least 5 minutes.

8. Turn on Electricity Supply

9. Set Chilled Water Temperature

Set the desired water temperature using temperature control knob. Refer to Billi Alpine User Guide.

10. Re-check Connections for Leaks

11. Explain Operation to User

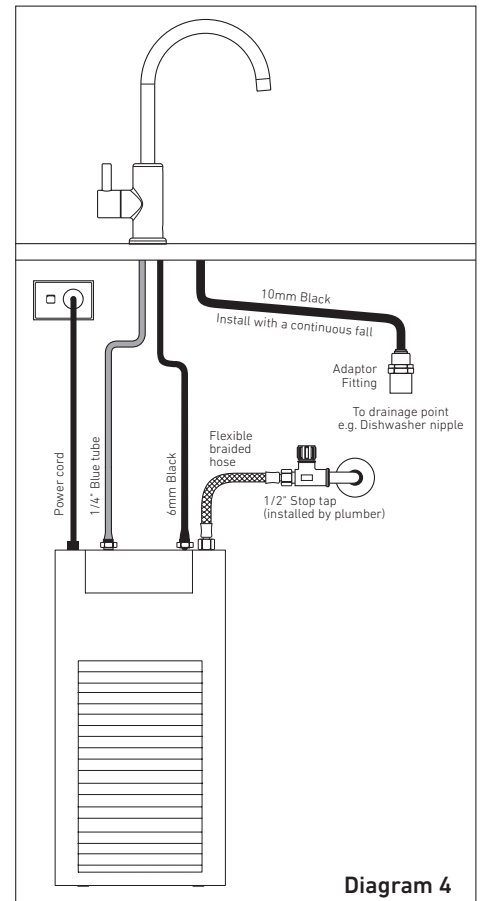
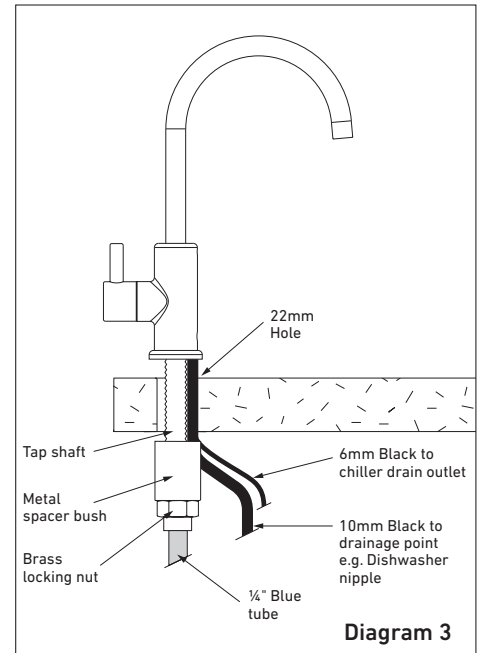

WARNINGS.

For continued safety of this appliance it must be installed, operated and maintained in accordance with the manufacturer's instructions.

- Your appliance should be installed by a suitably qualified tradesperson.
- For correct operation of this appliance it is essential to observe the instructions as outlined in this booklet.
- Filter replacement must be performed at intervals of not more than 6 months.
- Use this appliance only as directed in these instructions and only for its designed purpose.
- This appliance is not intended for use by persons (including children) with reduced physical, sensory or mental capabilities, or lack of experience and knowledge, unless they have been given supervision or instruction concerning use of the appliance by a person responsible for their safety.
- Children should be supervised to ensure that they do not play with the appliance.
- DANGER: The operation of the thermal cut-out indicates a possibly dangerous situation. Do not reset the thermal cut-out until the water heater has been serviced by a qualified person.
- WARNING: Do not connect any restrictor or pressure relief device to the vent pipe of this water heater if installed.
- If the supply cord is damaged, it must be replaced by the manufacturer, its service agent or similarly qualified persons in order to avoid a hazard.
- New hose-sets supplied with the appliance are to be used and old hose-sets should not be re-used.

As Billi UK Limited has a policy of continual improvement, all details are subject to change without notice. All goods are sold subject to our published terms and conditions.