

COMMERCIAL DATA SHEET

OmniOne Plus 9 XL & Paddle



Billi OmniOne Plus 9 with XL Levered Dispenser & Paddle Mixer

The OmniOne Plus 9 is the latest iteration of multifunction drinking water appliances from Billi.

Representing the perfect blend of innovation and sustainable design, the OmniOne integrates Billi's renowned water-cooling and energy reclaim technologies into a single space-saving undercounter module with the added bonus of hot water for the sink.

With a 30% uplift in performance, whisper quiet operation and ergonomic design, the OmniOne Plus 9 range is the ultimate inclusion to the modern workplace or facility tailored to your wellness and hygiene.

Streamlined and elegant, the XL levered dispenser offers boiling, chilled and sparkling output delivered safely by operating the position-sensitive levers, while hot water is supplied separately by our Paddle Mixer.



XL Levered Dispenser

Paddle Lever Mixer

OmniOne Plus 9 Under-Bench Unit



Features



*Certification pending completion

PRODUCT SPECIFICATIONS

Water type	Product code	Model name	Dispenser	Suggested no. of people	50° hot water capacity litres (initial drawdown)	50° hot water delivery litres per hour	Boiling water delivery (cups per hour)*	Chilled & Sparkling water delivery (cups per hour)	Power supply (amps)
BOILING CHILLED SPARKLING PLUS	926065LPUK	OmniOne Plus 9	XL Levered	Up to 60	9	60	180	220	13

* Based on a set volume of water being drawn every 30 seconds at an inlet temperature of average temperature 21°C. Each cup is equivalent to 170mL. Usage patterns and draw-off methods can impact recovery.

Accessories

992803 - 120mm Riser & Font

990726 - Tubing Extention Kit for Sparkling unit - 2mtrs



Finishes

Standard Finishes

CH - Chrome

BR - Brushed

MB - Matte Black

Special Order Finishes

MW - Matte White

RG - Rose Gold

BRG - Brushed Rose Gold

GM - Gun Metal Grey

UB - Urban Brass

Add the relevant Finish Code and the Country Identifier (UK) to the Product code to complete your specification eg 926065LPMBUK

TECHNICAL DRAWINGS

PRODUCT DIMENSIONS

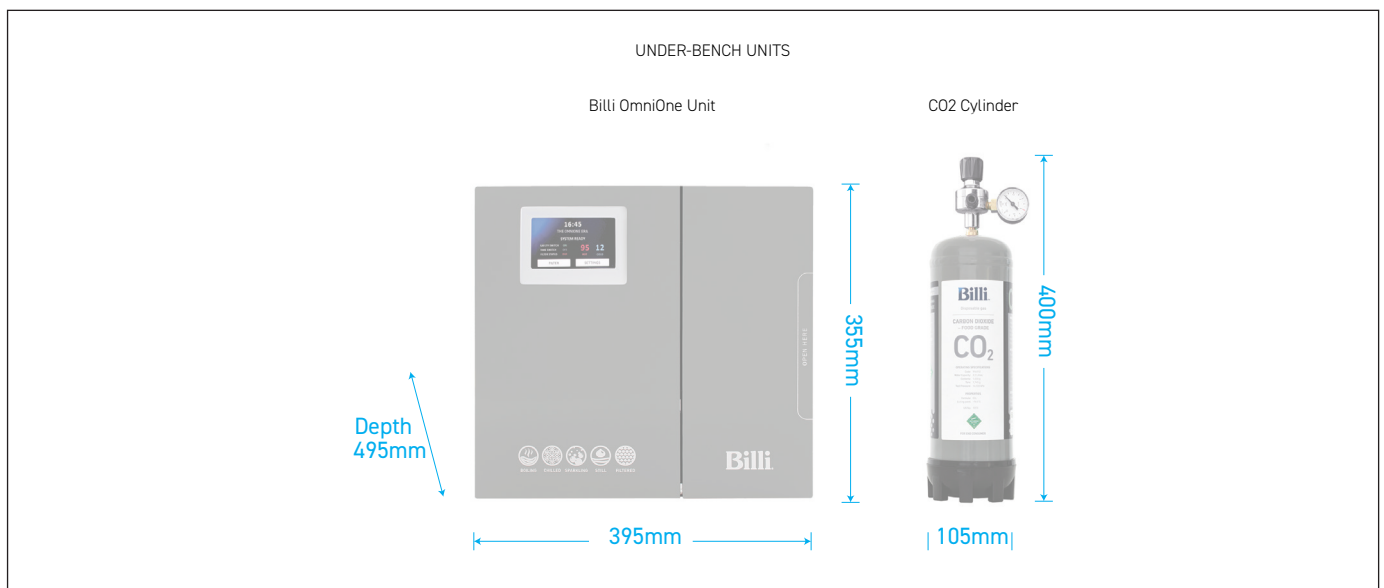
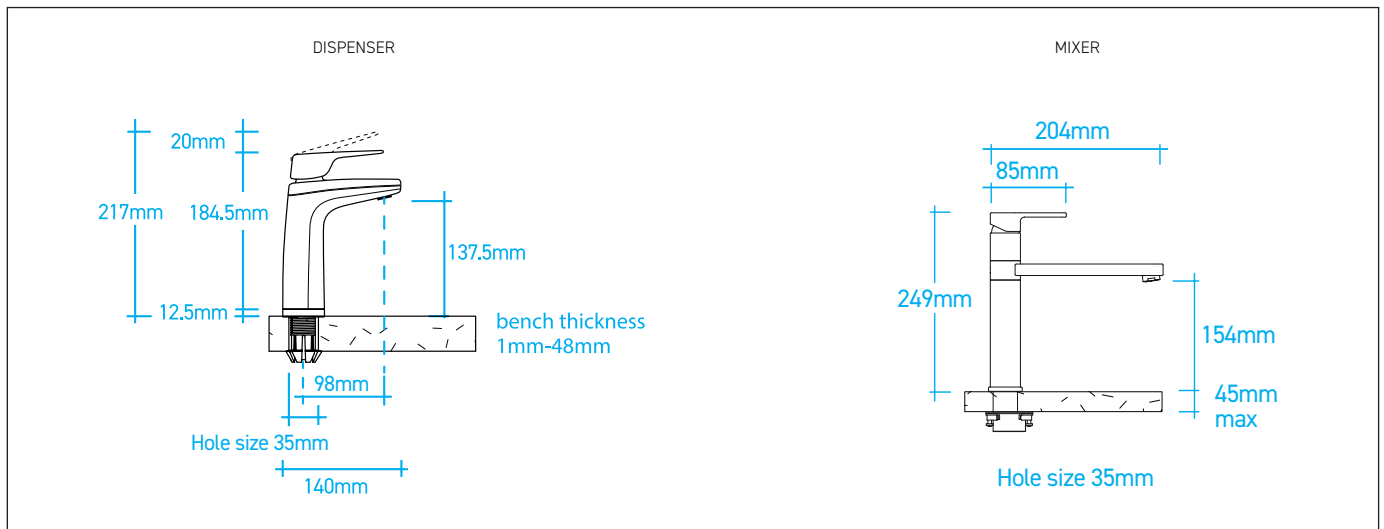

INSTALLATION REQUIREMENTS

PREFERRED INSTALLATION LAYOUT

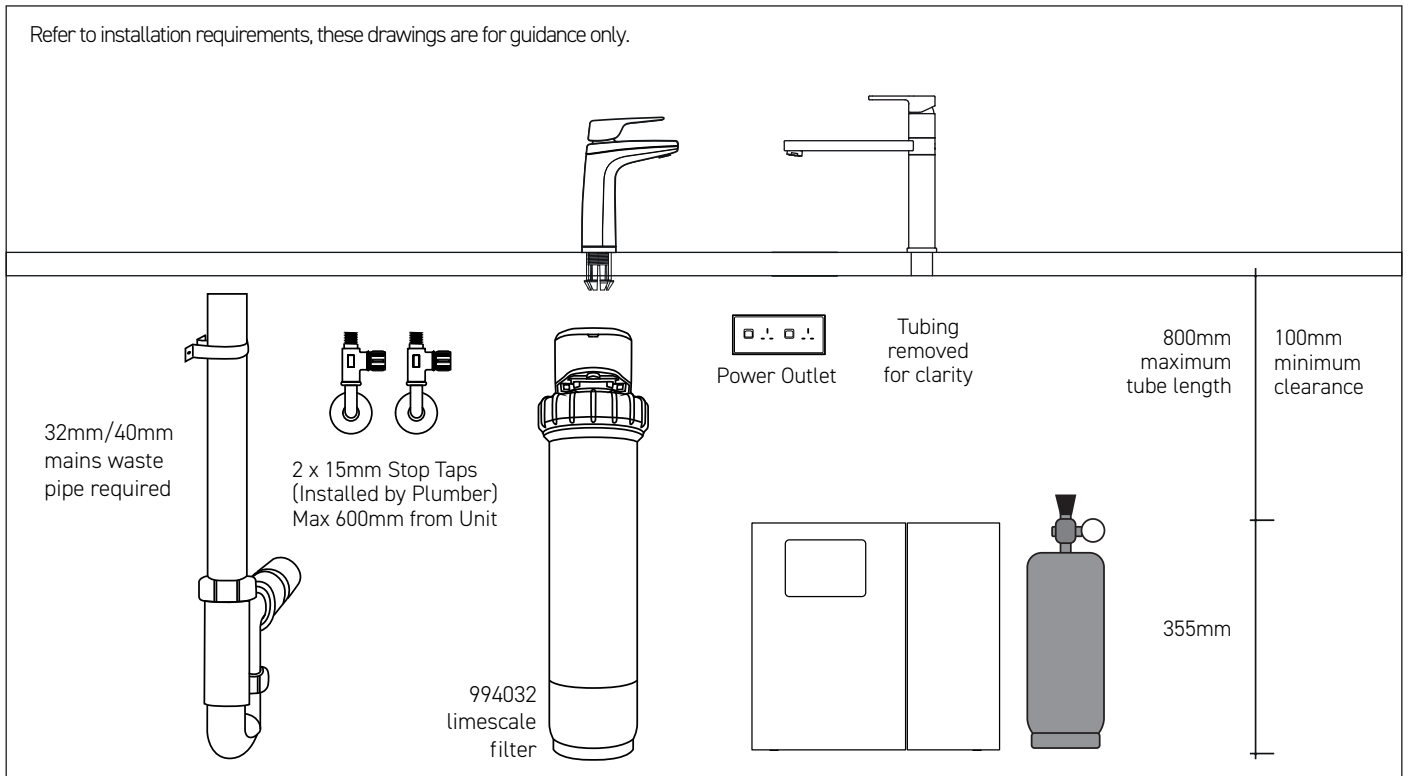

WATER SUPPLY

An accessible drinking water supply from a 15mm pipe with a minimum pressure of 4 bar static and 10 litres a minute flow should be located in the base unit of the installation location.

POWER SUPPLY

A 13amp single switched socket must be positioned at a high level and accessible within the cupboard. The unit comes with a 1 meter flex cord and plug.

WATER REQUIREMENTS

A 32mm/40mm mains waste pipe is required within the base unit. This pipe should include a trap or u-bend to prevent any unpleasant odours. If there is a spigot waste connection, two spigots are required to connect to the waste and condenser line.

FILTRATION

Billi's range of premium filters utilise BWT's unique Fibron X technology which provide superior taste, water quality, consistent filter life and peace of mind on the topic of hygiene.

Supplied: 994051 (5 micron)

On request: 994032 (recommended iX02 Limescale Filter)

CO₂ Cylinder

The CO₂ gas cylinder supplied must be secured in a suitable location. Each cylinder contains 1100g of CO₂ and should be installed in a well ventilated area. Each cylinder will provide 160 litres of sparkling water depending on the unit settings. The MSDS is available on www.billi-uk.com for a complete list of specifications and warnings. Replacement gas cylinders are available from Billi. CO₂ Cylinder - Order code 996911 and select chosen quantity (single, twin, 6-pack).

CERTIFICATIONS & COMPLIANCE*

Every Billi drinking water appliance is manufactured under a certified quality control system. All Billi commercial range models have been tested and comply with all required standards including: ISO 9001:2015, QEC 11627; WRAS certified*; WELL Cornerstone Member; BREAMM compliant; LEED compliant.

WARRANTY

The Billi OmniOne Range is covered by a comprehensive two year warranty on all parts and labour.

** Drawings are for guidance during specification, refer to Installation requirements for final install. All efforts are made to ensure Certifications & Compliance claims are current, however this is subject to change without notice.*

Billi™

Billi UK Limited

University Of Wolverhampton Science Park,
Technology Centre, Glaisher Drive,
Wolverhampton, WV10 9RU

P 020 7456 6789
E marketing@billi-uk.com
W www.billi-uk.com

visit us at

