

BilliTM



Install Guide

Quadra Sparkling

Introduction and Specification

Safety

The unit should be isolated from the electricity supply before removal of any covers. Great care must be employed when working with high pressure carbon dioxide, and in no cases should the maximum operating pressure of 58 psi (4 bar) be exceeded.

Introduction

This unit has been designed to work in an enclosed, under counter installation without the need for an additional ventilation kit, as cooling of the fridge system is provided by water from the mains supply rather than air cooling.

Specification

Dimensions	180mm(W) 360mm(D) 420mm(H)	Compressor	Cubigel B38G
Supply	220-240Vac/50Hz	This product contains fluorinated greenhouse gas with a GWP of 1430 in an hermetically sealed system	
Rated Input	200W - Cold 2150W - Boiling		
Rated Current	1.5A 10A	Refrigerant	R134a, 60g
Fuse Rating	5A 13A	Climatic Class	N
CO ₂ Pressure	40-50 PSI (2.7-3.4 bar)	Potable water inlet pressure	Internally regulated at 19 PSI (1.3 bar)
Compliance			

Installation and Commissioning

The chilled unit is designed to operate with the Billi™ range of tap/dispensing equipment and should not be operated in isolation from these units.

- Locate the machine in a suitable enclosure, Quadra Sparkling is designed to work without the need for additional ventilation, this is achieved by using water to cool the refrigeration system rather than air.

Note: At this stage do not connect the unit to the electrical supply.

CO2 Gas and Water Connections

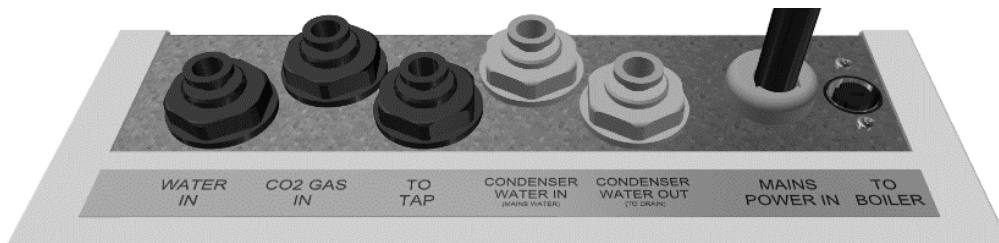

Drinking water and gas connections are via 6mm John Guest Speedfit fittings, which are black in colour.

Condenser water connections are via 1/4" John Guest Speedfit fittings, which are grey in colour. **NOTE: 6mm tubing must not be used with 1/4" fittings as this may lead to water leaks.**

- Connect "WATER IN" to the water supply from the parent boiler. After all connections are made the boiler unit should be on and ready to supply water to the cold unit. Water pressure in the chiller is internally regulated at 19 PSI (1.3 BAR).
- Connect the "CO2 GAS IN" to the regulator, ensuring the pressure is set to 40 PSI (2.7 bar), and turn on the supply.
- Connect "TO TAP" to the water dispense tap.
- Connect "CONDENSER WATER IN" to mains water and open the supply of water.
NOTE: This water supply to the "CONDENSER WATER IN" port must have a minimum pressure of 1.3Bar.
- Connect "CONDENSER WATER OUT" to drain.
- Connect the flying lead from the parent boiler to the socket labelled "TO BOILER".
- With the boiler ready to supply water plug in and turn on the chiller unit.
- The compressor will start, and the water pump will operate for approximately 20-30 seconds to fill the carbonator vessel. Verify that water is flowing from the "CONDENSER WATER OUT" to drain. The flow rate has been factory set to 5ml/s at 1.3 bar, so a low flow rate is expected to drain, however, this expected to be a constant flow and should not be dripping.
- Once the water pump has switched off dispense still water until all air is expelled from the tap and a smooth flow of water is established.
- Now dispense at least 1 ltr of soda water to help purge the system of any remaining air.
- After approximately 10 minutes, the compressor will stop as the chiller has reached its normal operating temperature.

Installation and Commissioning

Note: The time taken for the chiller to reach operating temperature will vary depending on ambient temperature, humidity and the temperature of the incoming water supply.

The Soda flow rate is factory set to dispense at 30 ml per second at a gas pressure of 40psi (2.7 bar). However, if an alternative flow rate is required follow the steps below:

1. Locate the flow adjuster screw on the side of the unit (Fig 1.).
2. To increase the flow rate turn the screw anti-clockwise.
3. To reduce flow rate turn the screw clockwise.
4. Adjustments can be made with either a large flat head screw driver or with a 6mm Alan key.
5. It is recommended to make incremental changes of no more than a quarter turn at a time until desired flow rate is achieved.

Fig 1.

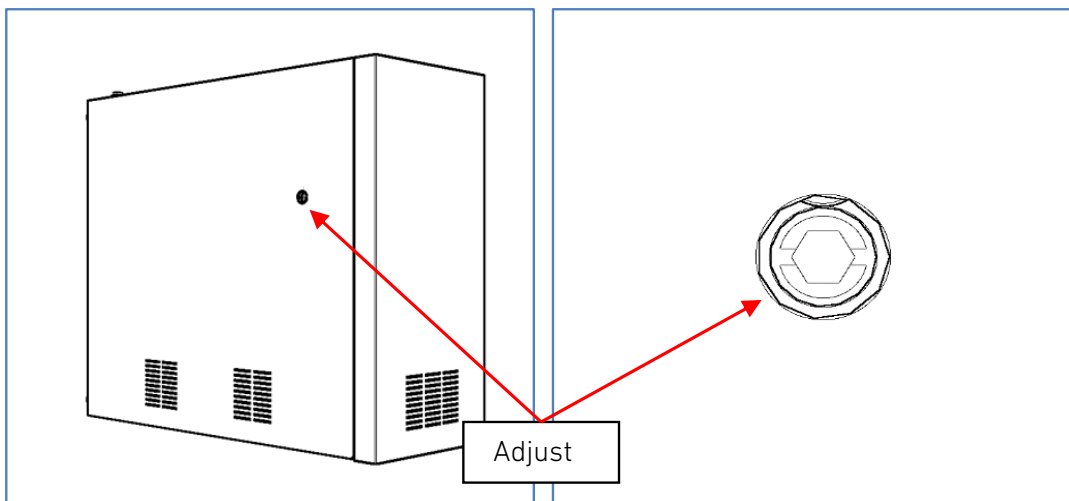

Installation and Commissioning

Electrical Circuit

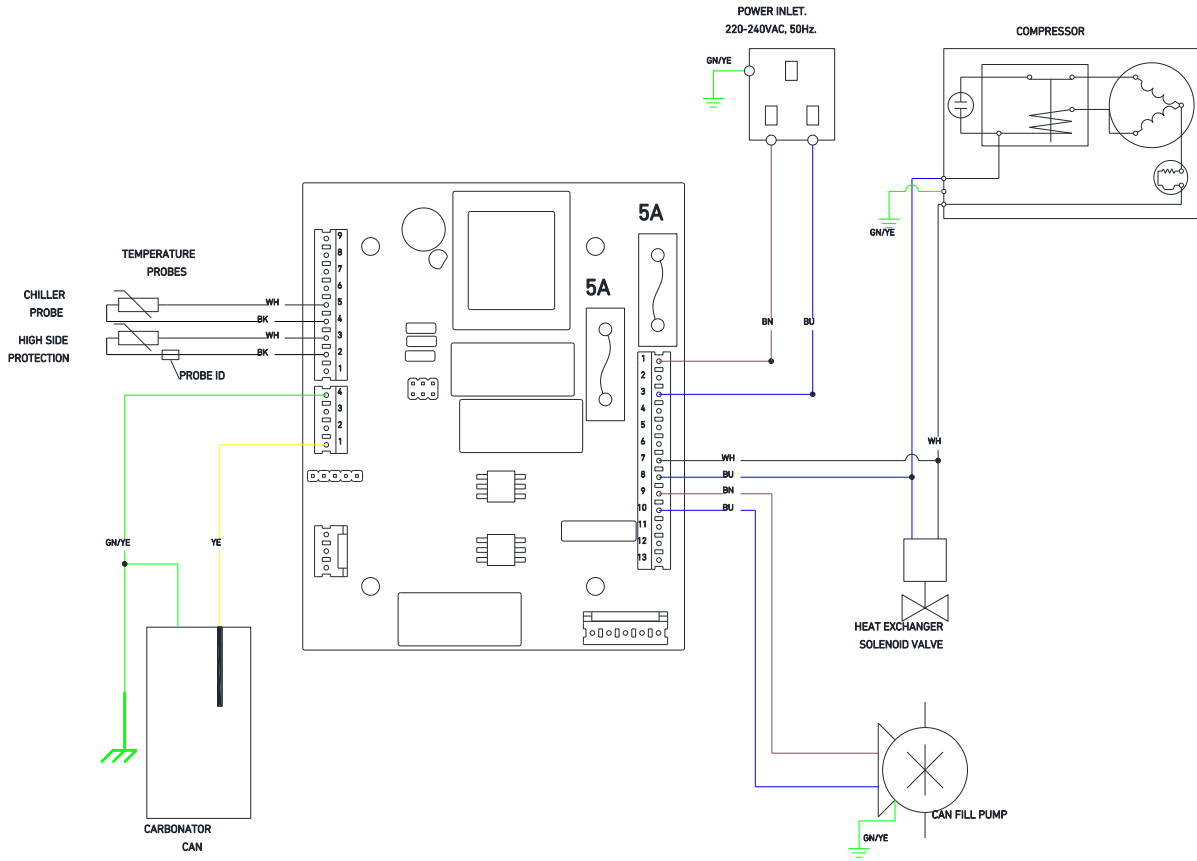

Water Circuit

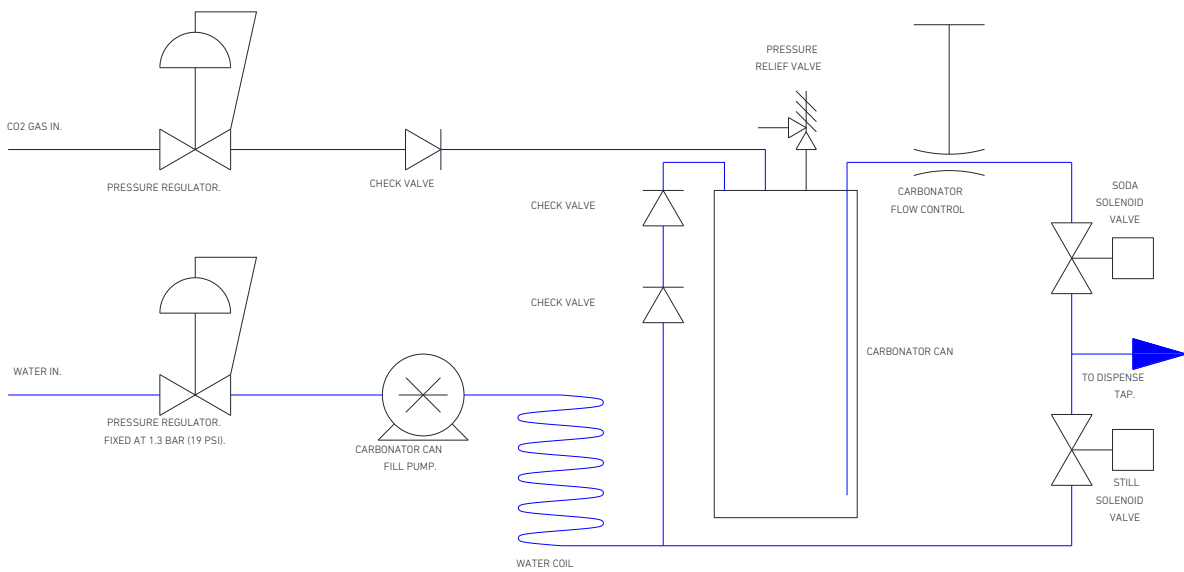

Fault Finding

Prior to any fault finding, please ensure all water connections to the chiller are sound and that the incoming water supply is turned on. Also ensure that all electrical connections to the chiller and in the chiller are secure and in good condition, the power is on and that the chiller has had adequate time to reach operating temperature.

NOTE: When checking electrical connections ensure mains power is switched off.

Symptom	Possible Cause	Corrective Action
No Water Dispensing	Water pressure regulator	Check water can flow through the regulator. Replace if necessary.
	Frozen chiller block	Ensure temperature probe is fully inserted into the dry block. If necessary replace probe.
	Faulty dispense valve	Check valve can open on demand. Replace valve block if necessary.
	Flying lead from boiler not connected.	Connect flying lead from boiler to the chiller unit.
	Faulty dispense control board	Check and replace if necessary.
	Pump not running during still water dispense.	Check for pump timeout, cycle power off & on. Check supply to water pump (230V AC), if voltage present & pump inoperative - replace pump. If voltage not present & pump is not timed out, check main control board fuses. If necessary replace control board.
No Carbonated Water	No CO2 pressure, check by operating pressure relief valve on carbonator can	Check CO2 bottle, regulator and non-return valve. Supply pressure should be 40 psi (2.7 bar), adjust or replace as necessary.
	Water pressure regulator	Check water can flow through the regulator. Replace if necessary.
	Frozen chiller block	Ensure temperature probe is fully inserted into the dry block. If necessary replace probe.
	Faulty dispense valve	Check valve can open on demand. Replace valve block if necessary.
	Flying lead from boiler not connected.	Connect flying lead from boiler to the chiller unit.
	Faulty dispense control board	Check and replace if necessary.
Carbonator Can Not Filling	Check carbonator probe for possible short circuit to ground. Check for pump timeout, cycle power off & on then purge carbonator. Check supply to water pump (230V AC), if voltage present & pump inoperative - replace pump. If voltage not present & pump is not timed out, check control board fuses. If necessary replace control board.	

Fault Finding

Symptom	Possible Cause	Corrective Action
Poor Quality Carbonation	Incorrect CO2 Pressure	Check CO2 bottle, regulator and non- return valve. Supply pressure should be 40 psi (2.7 bar), adjust or replace as necessary.
	Air in Carbonator Can	Isolate water supply and operate the carb water tap until gas is expelled. Allow gas to expel for 5 seconds. Restore water supply and allow the can to refill.
	Residue in Carbonator Can	After prolonged use, a surface film can develop within the carbonator can. This can be removed by flushing the system using a solution of citric acid.
	Carbonator can is overfilled	If pump runs continuously, check connections to can level probe, if problem persists replace the PCB.
Warm Drinks	Insufficient water flow through the fridge heat exchanger.	Check for water flow from the "FRIDGE WATER OUT" port whilst the fridge is running. The flow rate should be a minimum of 5ml/s with a minimum water inlet pressure of 1.3Bar. Check supply voltage to the heat exchanger solenoid valve (230V AC) whilst the fridge is running. Replace valve if necessary. If supply not present move on to the compressor. The supply to the solenoid valve and the compressor are linked.
	Compressor not running	Fridge overheat. Switch off the unit and allow to cool. Ensure the solenoid valve operates and sufficient water flow is available through the heat exchanger. If overheating persists return for repair. If no overheat is found check voltage to compressor (230V AC). If voltage not present check the temperature probes and replace if required. If voltage not present check control board fuses. If necessary replace control board.
	Control board not operating.	Check control board and main plug fuses. If necessary replace control board.
	Fridge failure	If compressor is running & sufficient water is flowing through the heat exchanger and there is no cooling, return for repair.

Fridge Condenser Care & Maintenance

After a period of operation it is possible that, especially in hard water areas, scale deposits may build up inside the fridge heat exchanger. To help reduce this it is recommended that the water supply to the "CONDENSER WATER IN" is fitted with a chemical or magnet water conditioning unit. These units work to reduce the possibility of calcium particles be deposited in the heat exchanger.

If the water supply does not contain a conditioning system calcium build-up may reduce water flow and potentially lead to a blockage. To prevent this, periodic cleaning of the heat exchanger may be required using a descaling solution. The frequency of this will be dependent on the hardness of the water and the demand on the chiller.

Removal, Transportation and Disposal

Important: Before removal from the installation, ensure all electrical, product and gas connections are disconnected.

Disposal of Scrap Units

It is illegal to simply scrap a refrigeration unit. Before a unit can be scrapped it must first have the gas removed by a specialist using special equipment. Please contact Billi UK, who will be happy to provide a quotation for disposal.

Transportation

Important: This unit must be transported in an upright position

As with all refrigeration systems, irreparable damage can be caused by laying the unit on its side or even transporting upside down. Where the unit is transported by a carrier, the carton should always be marked in a conspicuous manner, the correct upright position in which it must be handled.

If a unit has been transported incorrectly it should be placed in the correct upright position and left for 24 hours before attempting to run the system.

Failure to observe the above precautions could seriously damage the system, and would void any warranty.

Installation requirements.

XL

Unpacking your Billi Quadra Sparking Unit

Before commencing installation, carefully check for any damage to outer carton, inner liner, appliance metalwork, pipework fittings and electrical power cord. If damage is found, please photograph and record details for use if a claim is to be made.

WARNINGS relating to this appliance must be read before commencing installation. Refer to page 8.

When unpacking your appliance, ensure you have identified the following components:

1. Boiling water module
2. Chilled water module
3. CO₂ cylinder
CO₂ regulator
4. Dispenser
5. Tube spring clamps x 2
6. Natural and 2 x black Ø6 mm PE tubes with stem elbows fitted
7. 600mm flexible braided hose
8. Filter cartridge (installed)
9. User guide
10. Warranty registration card
11. Warning label

Determine Unit Location

Plan the installation carefully, taking into consideration dispenser tube lengths, position of power and water outlets, ventilation airspace requirements and access for service. Refer to diagrams 1, 2, 3a, 3b and 4. Diagram 4 shows minimum clearances required around the units for ventilation

Water Supply

A single cold water supply point with a ½" BSP stop tap is required. Stop tap is to be installed in an easily accessible position, within 600 mm of the inlet to the boiling water module.

Sparkling chilled water module is supplied from an outlet fitting on the Boiling water module.

Dynamic supply pressure: Min. 250 kPa, max. 1000 kPa

NOTE: Quadra Plus models require an additional ½" BSP stop tap water supply tap.

Refer to instructions on Page 6.

Supply temp: Min. 5°C, max. 30°C

Do not install with water that is microbiologically unsafe or with water of unknown quality without adequate disinfection before or after the system. Systems certified for cyst reduction may be used on disinfected water that may contain filterable cysts.

Power Requirements

Quadra Sparkling models 460 and Plus 9 require 2 x 13 amp sockets, installed in an accessible position. Refer to Diagram 1.

Quadra Sparkling models 4100 and Plus 15 boiling module require a separate 20amp double pole with a dedicated circuit. Power circuits must be fitted with an earth leakage protection device (RCD). Both boiling and chilled water module are supplied with flex cord and plug.

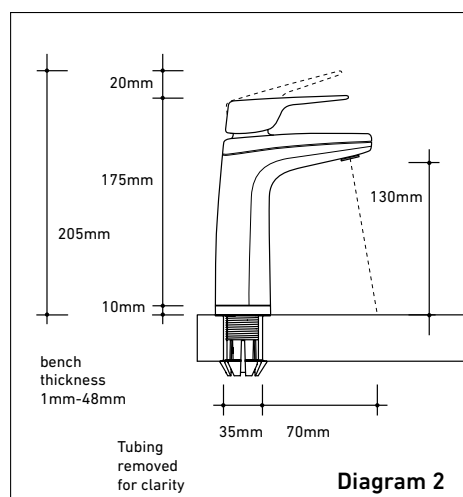
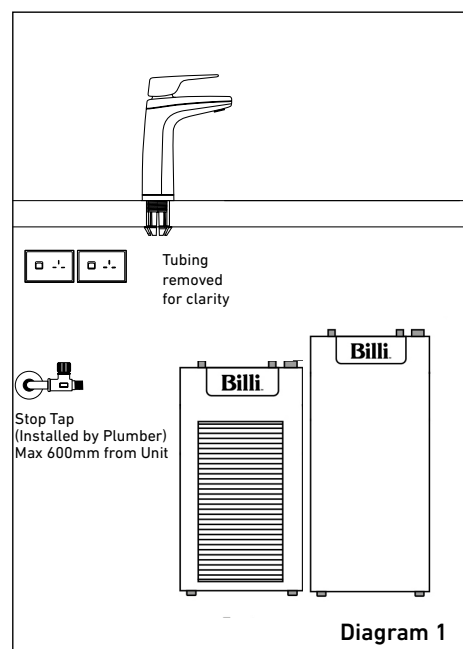

Installation requirements.

XL

Boiling water module dimensions

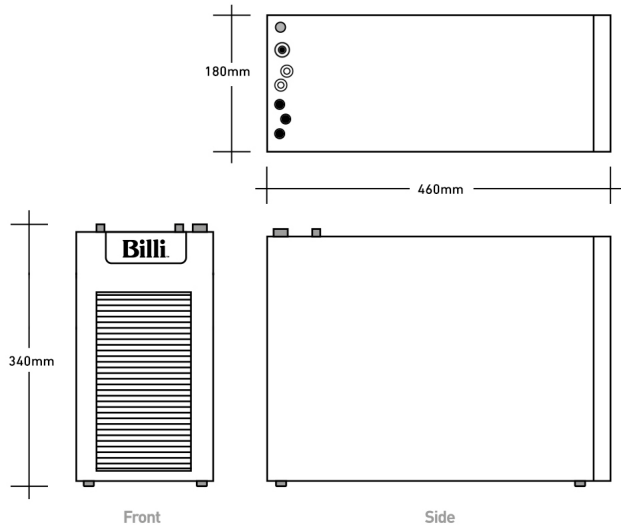

Chilled water module dimensions

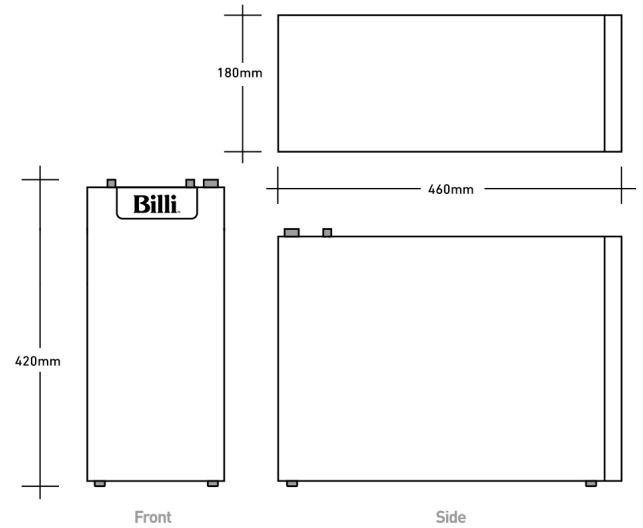

Quadra Sparkling Suggested layout - TOP

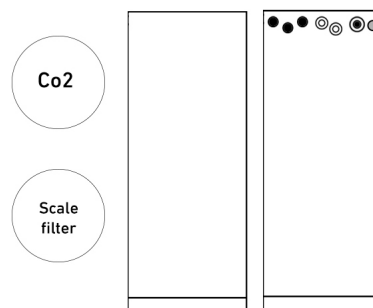

Installing the dispenser. XL

IMPORTANT: This Billi appliance is to be installed by a licensed trades person in accordance with AS/NZS 3500.1 and AS/NZ 3500.2 and in compliance with applicable state regulatory requirements. For correct operation of this appliance, it is essential to observe the manufacturer's instructions.

1. Install Dispenser Assembly

Determine position of dispenser mounting hole in sink top or bench top. Dispenser base template (Diagram 5) may be cut out and used to assist in correct positioning. Refer to Diagram 2 for clearances allowed. Hole size required is $\varnothing 32\text{mm}$.

The Billi XL dispenser is supplied with base assembly preassembled into dispenser upper and this must be first removed prior to starting installation. Using allen key supplied in installation kit, remove chrome plated M4 screw from rear of housing. Twist base casting around 60° and then slide assembly out of upper housing. Carefully pull tubing and electrical cable and plug through base assembly.

—Stainless Steel Sinktop

A suitable 32mm hole punch (Part no: 857901) is available as an accessory from Billi Pty Ltd. If possible, cut hole with die mounted below the sinktop surface so that burr is pulled downwards. Alternatively, remove burr and radius edge of hole with fine file. This allows barbed dispenser mount to slide smoothly into mounting hole.

—Timber/Laminate Benchtop

Maximum benchtop thickness is 50mm. Cut 32mm hole in appropriate position. When drilling through a particle board bench top, take care to avoid substrate chipping and breaking away as drill breaks through underside surface. We recommend drilling a small pilot hole through benchtop, partially drilling the 32mm hole from underneath and then completing drilling the hole from above. The large 30mm washer supplied may be used to secure barb where bench top substrate has chipped away.

—Granite/Marble Benchtop

For granite or marble bench tops we recommend that you use a certified stone mason to pre-drill the hole.

2. Activate Dispenser Swivel Feature

The XL dispenser can be installed either as locked into straight position or able to swivel 45° in either direction. To activate the swivel feature of your dispenser, remove the locking piece from the dispenser base. Simply push out the piece as show in Diagram 6. This will allow the tap to swivel to the left and right.

3. Fit Dispenser Base

- Cut a 32mm hole in sinktop or benchtop. Remove burr if protruding upwards.
- Push barbed mounting shaft through mount hole.
- Insert barb locking bush as shown in Diagram 7. Finger tighten nut.
- Ensure barb is centred in mount hole before tightening. Check position of base ring and gasket.
- Moderately tighten locking nut using multigrips or spanner. Take care to avoid overtightening nut which may break the plastic threaded shaft.
- Place large D washer over thread as shown in Diagram 7.
- Cut off excess threaded shaft with a hacksaw, using washer as a cutting guide. (Diagram 8)

IMPORTANT: Remove burrs and check internal bore is completely smooth.

4. Fit Dispenser Head Assembly

- Feed dispenser tubing and loom through center hole in the following order:
 - Dispenser power cord
 - Silicone tubes
 - Blue PE tube.
- Gently pull hoses from under the bench top. Do not attempt to force tubing through with a pointed object as silicone tube is easily punctured. Check tubing is not kinked or twisted. Refer to Diagram 9.
- Turn dispenser head assembly to approximately 60° from the straight ahead position of dispenser base. Slide head assembly onto base assembly whilst gently pulling tubing downwards from underneath to prevent tubing bunching and kinking. Head retaining lugs will pass nut and slide down the 3 grooves on the swivel bearing.
- Once fully down, turn dispenser to straight ahead position. Fit chrome plated M4 retaining screw to lower rear threaded hole and tighten using the allen key supplied. If swivel feature is activated, check dispenser now swivels smoothly 45° in each direction.

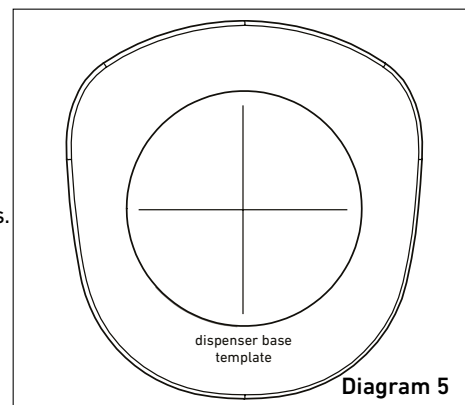

Diagram 5

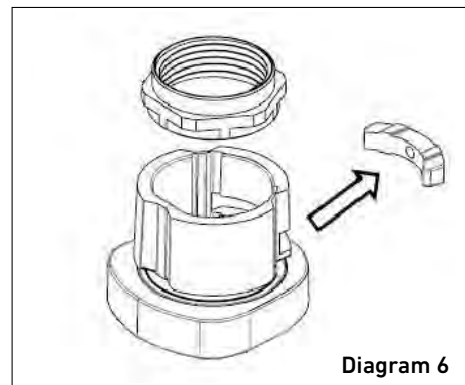

Diagram 6

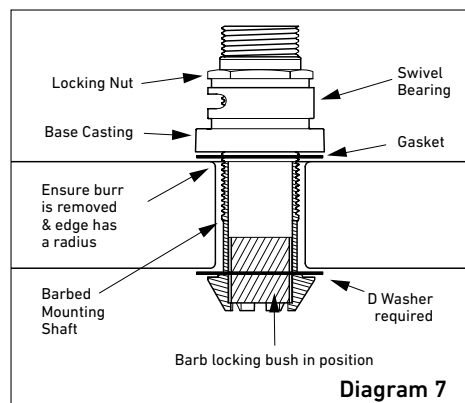

Diagram 7

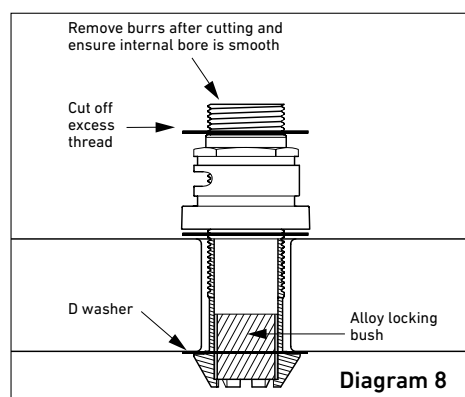

Diagram 8

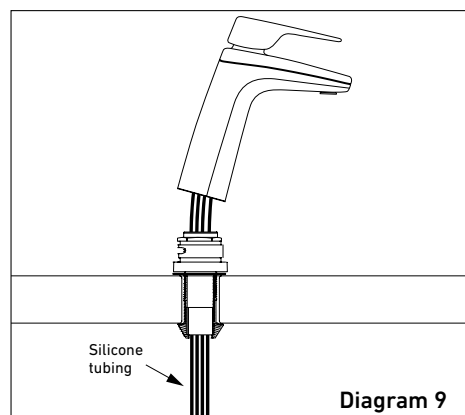

Diagram 9

Commissioning Checklist

WARNINGS.

CHECK EACH OF THE FOLLOWING ITEMS:

- Filter packing foam removed from under filter cannister.
- Dispenser mounted securely – M4 chrome retaining screw fitted.
- Dispenser swivels 45° in each direction (if activated) - locking piece is removed.
- Tubing is cut to correct lengths and not kinked or sagging. Red and grey silicone tubes have a continual fall.
- Tubing secured correctly – nuts and spring clips fitted.
- Water main flushed before connection to unit.
- Unit connected to COLD water supply.
- Correct air clearances around unit.
- Power circuit fitted with an RCD – earth leakage protection device.
- Sawdust cleaned out of cupboard area.
- Door vents and spacer pads fitted correctly
- Initial program settings correctly set for dispenser tube length.
- Unit heating and cooling (after initial fill). Red and blue dispenser icons flashing (or on continually when reached correct temperature).
- Boiling and chilled water flow correct.

If any problems or difficulties arise contact **Billi UK Limited** on **020 7456 6789**. To validate your warranty refer to the warranty card or validate online at **www.billi-uk.com**.

For information on our filtration and service contracts please contact Billi Customer Service on 020 7456 6789 or **client.care@billi-uk.com**.

For continued safety of this appliance it must be installed, operated and maintained in accordance with the manufacturer's instructions. For correct operation of this appliance, it is essential to observe the instructions as outlined in this booklet.

- Your appliance should be installed by a suitably qualified tradesperson.
- For correct operation of this appliance it is essential to observe the instructions as outlined in this booklet.
- Do not use this appliance with water that is microbiologically unsafe or with water of unknown quality without adequate disinfection before or after the system. Systems certified for cyst reduction may be used on disinfected water that may contain filterable cysts.
- Filter replacement must be performed at intervals of not more than 12 months.
- Use this appliance only as directed in these instructions and relevant Billi User Guide and only for its designed purpose.
- Do not install unit if power cord is damaged.
- This appliance is not intended for use by persons (including children) with reduced physical, sensory or mental capabilities, or lack of experience and knowledge, unless they have been given supervision or instruction concerning use of the appliance by a person responsible for their safety.
- Always activate boiling water safety lock switch where children or mentally disabled persons could access the appliance.
- This appliance is designed for indoor installation only and must not be exposed to direct sunlight, rain and excessive heat, cold, damp or dust.
- Do not store solvents or corrosive chemicals or other flammable items on or around this appliance
- DANGER:** High Voltages. Power supply must be disconnected before cleaning or removing and outer covers form the appliance. Any service or unit repairs must be performed by a trained and suitably qualified technician.
- Children should be supervised to ensure that they do not play with the appliance.
- DANGER:** The operation of the thermal cut-out indicates a possibly dangerous situation. Do not reset the thermal cut-out until the water heater has been serviced by a qualified person.
- WARNING:** Do not connect any restrictor or pressure relief device to the vent pipe of this water heater if installed.
- If the supply cord is damaged, it must be replaced by the manufacturer, its service agent or similarly qualified persons in order to avoid a hazard.
- New hose-sets supplied with the appliance are to be used and old hose-sets should not be re-used.
- Packaging material including plastic bags must be kept out of reach of children and disposed of according to local regulations.
- If the appliance has been turned upside down during transport and handling, wait for at least 8 hours before switching appliance on.

As Billi UK Limited has a policy of continual improvement, all details are subject to change without notice. All goods are sold subject to our published terms and conditions. Billi is a registered trademark.

© 2019

QSIG0519